

Contact Details

Before using the product, please check the guide pages at the front of this catalog.

Internet

<https://www.daikinpmc.com/en/>

For latest information, PDF catalogs and operation manuals

Inline Check Valve



JIS graphic symbols for hydraulic system

Features

- Installed in a hydraulic line parallel to the line, the check valve opens when the pressure reaches the cracking pressure, allowing fluid to flow only in one direction and blocking the flow in the reverse direction.

Nomenclature

※ - HDIN - ※ ※ ※ - ※ ※

1 2 3 4 5

1 Applicable fluid code

No designation: Petroleum-based hydraulic fluid, water-glycol hydraulic fluid

F: Phosphate ester hydraulic fluid *¹

2 Model No.

HDIN: H series inline check valve

3 Connections

T: Screw connection type

F: Flange connection type

4 Nominal diameter

03: 3/8

06: 3/4

10: 1 1/4

12: 1 1/2

16: 2

24: 3

5 Cracking pressure code

See the cracking pressure table below.

Note: *¹ "F" is not necessary even for phosphate ester hydraulic fluids in the case of the screw connection type (T).

5 : Cracking pressure table

Cracking pressure code	0	01	015	02	05	10	12	15	20	25	30	35	45	56	60	90
Model No.	Cracking pressure MPa {kgf/cm ² }															
	0 {0}	0.01 {0.1}	0.015 {0.15}	0.02 {0.2}	0.05 {0.5}	0.1 {1}	0.12 {1.2}	0.15 {1.5}	0.2 {2}	0.25 {2.5}	0.3 {3}	0.35 {3.5}	0.45 {4.5}	0.56 {5.6}	0.6 {6}	0.9 {9}
HDIN-T03	✓	-	-	✓	✓	✓	-	✓	✓	-	-	✓	✓	✓	✓	✓
HDIN-T06	✓	-	✓	✓	✓	✓	-	✓	✓	-	-	✓	✓	✓	✓	✓
HDIN-F06	✓	-	✓	✓	✓	✓	-	✓	✓	-	-	✓	✓	✓	✓	✓
HDIN-T10	✓	-	-	✓	✓	✓	✓	✓	✓	✓	✓	✓	✓	-	✓	-
HDIN-F10	✓	-	-	✓	✓	✓	✓	✓	✓	✓	✓	✓	✓	-	✓	-
HDIN-F12	✓	-	-	-	✓	✓	-	✓	✓	-	-	✓	✓	-	-	-
HDIN-F16	✓	-	-	✓	✓	✓	-	✓	✓	✓	-	✓	✓	-	✓	-
HDIN-F24	✓	✓	-	-	✓	✓	-	-	✓	-	-	✓	✓	-	-	-

Specifications

Model code	Nominal diameter	Maximum operating pressure MPa {kgf/cm ² }	Maximum flow rate L/min	Mass kg	
HDIN-T03-※※	3/8	21 {210}	30	0.3	
HDIN-T06-※※	3/4		75	190	0.7
HDIN-F06-※※					3.2
HDIN-T10-※※	1 1/4		190	240	2.7
HDIN-F10-※※					6.9
HDIN-F12-※※	1 1/2		370	1060	13
HDIN-F16-※※	2				16
HDIN-F24-※※	3		43		

Note: The mass of the flange mount type valve (F) includes the mass of the flange and bolts.

Accessories (Flange mount type)

Flange (JIS B 2291 SSA), O-ring, mounting bolts

Handling

- Valves of cracking pressure type "0" (cracking pressure of 0 MPa {0 kgf/cm²}) need to be installed with the inlet port facing downward.

Contact Details

Before using the product, please check the guide pages at the front of this catalog.

Internet

<https://www.daikinpmc.com/en/>

For latest information, PDF catalogs and operation manuals

Performance curves: Pressure drop characteristics (viscosity: 32 mm²/s {cSt})

HDIN-T03

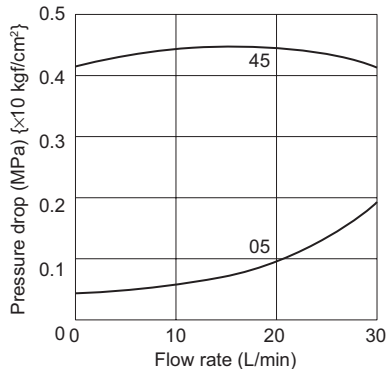

HDIN-×06

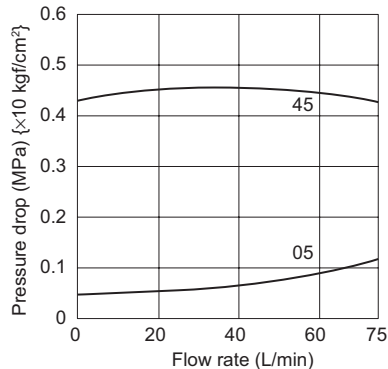

HDIN-×10

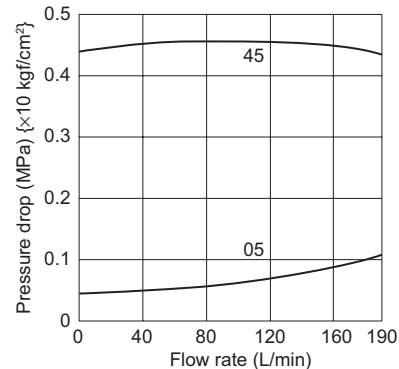

HDIN-F12

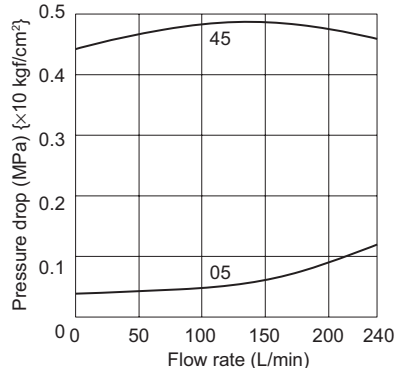

HDIN-F16

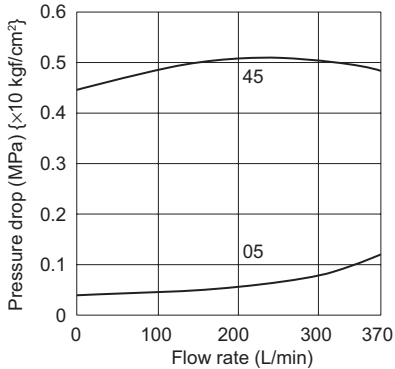

HDIN-F24

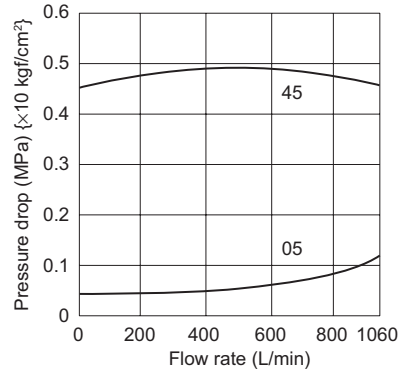

External dimension diagram

HDIN-T××

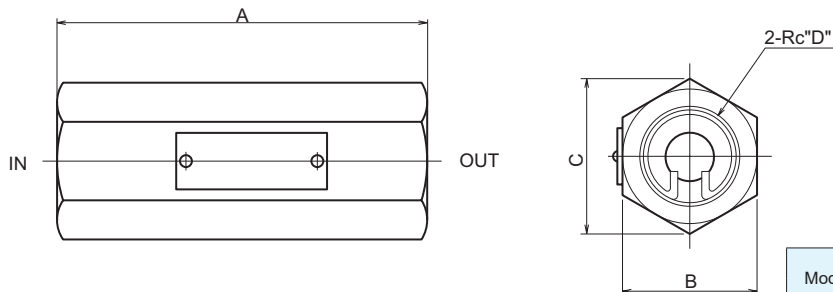

Model No.	Dimensions			
	A	B	C	D
HDIN-T03	76	27	31.2	⅜
HDIN-T06	98.4	36	41.6	¾
HDIN-T10	133	60	69.3	1¼

HDIN-F××

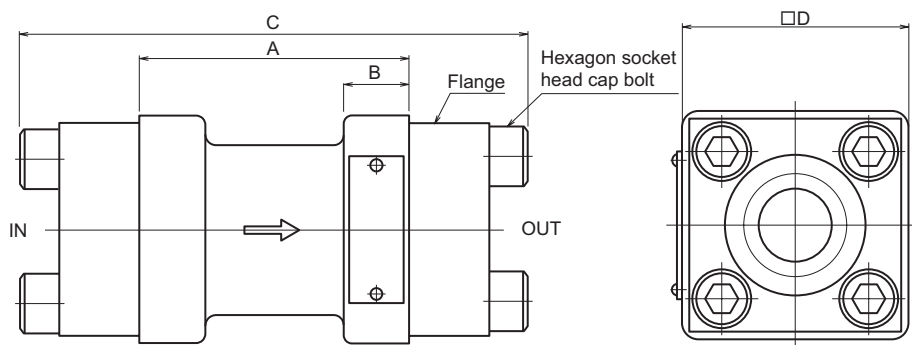

Model No.	Dimensions				Flange	Hexagon socket head cap bolt
	A	B	C	D		
HDIN-F06	74	18	138	62	JIS B 2291 SSA20	M10 × 40
HDIN-F10	95	25	175	80	JIS B 2291 SSA32	M12 × 45
HDIN-F12	110	30	214	96	JIS B 2291 SSA40	M16 × 60
HDIN-F16	125	30	229	105	JIS B 2291 SSA50	M16 × 60
HDIN-F24	210	40	344	148	JIS B 2291 SSA80	M22 × 80

Contact Details

Before using the product, please check the guide pages at the front of this catalog.

Internet

<https://www.daikinpmc.com/en/>

For latest information, PDF catalogs and operation manuals

Sectional structural diagram

HDIN-T**

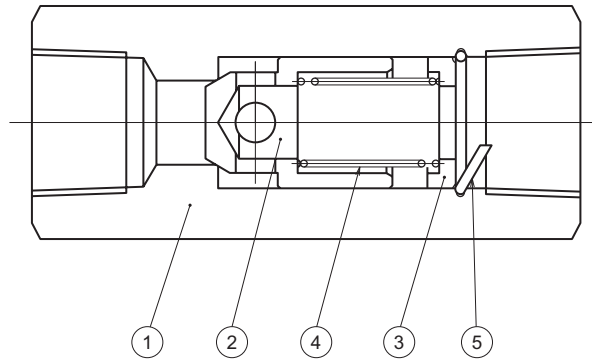

HDIN-F**

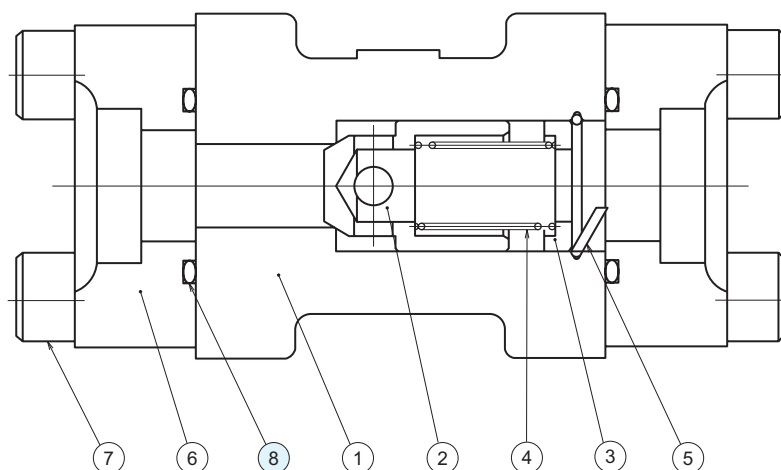

Sealing part table

Model No.	Part No.	Name	Quantity	Part specifications
HDIN-F06	8	O-ring	2	JIS B2401 1B G30
HDIN-F10		O-ring	2	JIS B2401 1B G40
HDIN-F12		O-ring	2	JIS B2401 1B G50
HDIN-F16		O-ring	2	JIS B2401 1B G60
HDIN-F24		O-ring	2	JIS B2401 1B G85