

## 3/8 Low Wattage Type Solenoid Valve



### Features

- When combined with a DAIKIN hybrid hydraulic system (inverter-driven energy-saving hydraulic unit), the ideal system configuration for significant power savings.
- High energy savings with a holding power of 5 W (87% reduction compared to DAIKIN solenoid valves)
- This valve can be driven directly with a PLC (programmable logic controller) and also makes it possible to reduce initial costs when designing machines with low power specifications.
- This is a low-wattage, high-spec. solenoid valve with a high maximum working pressure of 16 MPa and large maximum flow rate of 80 L/min.

### Nomenclature

**LS - G 03 - ※ ※ P - 10 - ※※※**

1      2   3      4   5   6      7      8

**1 Model No.**

LS: Low-wattage type solenoid valve

**2 Connections**

G: Gasket mount type

**3 Nominal diameter**

03: 3/8

**4 Spool code (See the model table.)**

**5 Spool operating method (See the model table.)**

C: Spring center type  
 B: Spring offset type (with SOL.b)  
 D: No-spring type (with detent)

**6 Voltage code (See the solenoid specification table.)**

P: DC24V

**7 Design No. (The design No. is subject to change.)**

**8 Option code (See the option code table.)**

### Specifications

Model No.	Nominal diameter	Maximum operating pressure MPa {kgf/cm <sup>2</sup> }	Maximum flow rate*1 L/min	Permissible back pressure MPa {kgf/cm <sup>2</sup> }	Maximum switching frequency Times per minute
LS-G03-※※P-10-※※※	3/8	16 {160}	80	16 {160}	120

Note: \*1. The maximum flow rate varies depending on the model and pressure. For details, refer to the pressure-flow rate characteristics in the Model List.

### 6 : Solenoid specification table

Voltage code	Power supply voltage	Holding current (A)	Holding power (W)	Permissible voltage fluctuation (%)	Time rating	Insulation resistance	Withstand voltage	Insulation type
P	DC 24V	0.22	5	90 to 110	Continuous	50MΩ	AC 1500 V, 1 minute	Type B (Coils: F class)

Note: The electric current and power indicated are the values at 20°C.

**4 5 : Model table**

Model code	JIS graphic symbols for hydraulic system	Power supply	Pressure - flow rate characteristics (See the graphs.)			Pressure drop characteristics (See the graphs.)		
						P→A P→B	A→T B→T	P→T
LS-G03-2C		DC	A	c	c	(3)	(2)	-
LS-G03-3C			B	d	d	(7)	(7)	(7)
LS-G03-4C			C	a	a	(3)	(6)	-
LS-G03-2B			D	e	f	(5)	(1)	-
LS-G03-2D			B	b	b	(5)	(4)	-

Note: The flow rates indicated are the maximum flow rate at which valve operation (switching) is still possible when 90% of the rated voltage is applied after the solenoid temperature has risen to saturation.

**8 : Option code table**

Symbol of option type	Option details			
No designation	Terminal box type	With lamp	With earth terminal	Without surge killer
N				Surge killer
NR				With surge killer (with resistance)
E				Without surge killer

Note: ○ If two or more options are selected, sort the option codes in alphanumeric order.

**Performance curves (viscosity: 32 mm<sup>2</sup>/s {cSt})**

Pressure – Flow rate characteristics

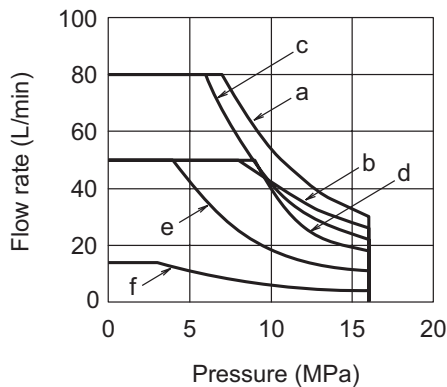
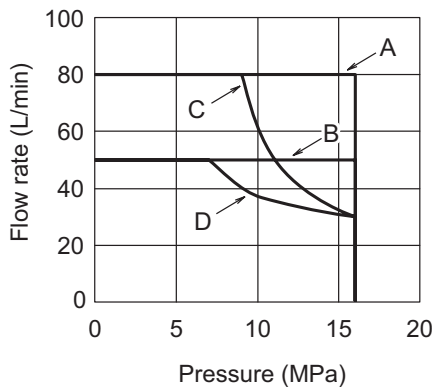

Pressure drop characteristics

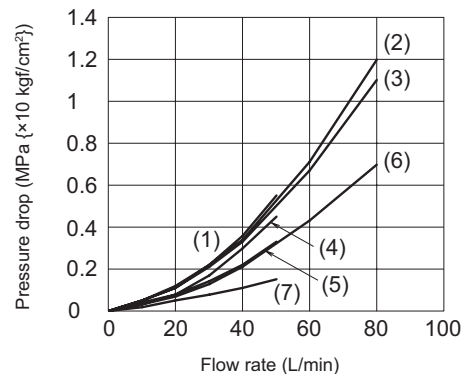

Note: ○ The flow rates shown in the graphs are the maximum flow rates under which operation (switching) of the valve is possible under the following conditions.

DC	With the maximum attainable temperature rise achieved, 90% of rated voltage applied
----	---

### Contact Details

Before using the product, please check the guide pages at the front of this catalog.

Internet

<https://www.daikinpmc.com/en/>

For latest information, PDF catalogs and operation manuals

## Operation time (sec)

Power supply	Applicable wiring method	Operating direction	Operation time
DC	Terminal box type	Excitation	0.09 to 0.24
		Spring return	0.04 to 0.07

## Mass (kg)

Double solenoid	Single solenoid
5.8	4.4

Note: ○ The operation time may change slightly depending on the spool code, conditions of use (pressure, flow rate, hydraulic fluid viscosity, etc.).

## Sub-plate model code

- The sub-plate is not provided with the valve. Order it separately if required by specifying the model code given in the table below.

Model code	Nominal diameter	Connection port diameter	Mass (kg)
JS-03M	3/8	Rc3/8	2.5
JS-03M04		Rc1/2	2.2

Refer to Page S-9 for the dimensions of the sub-plate.

## Accessories

Hexagon socket head cap bolt	Number of bolts	Tightening torque N·m{kgf·cm}
M6×35	4	12 to 15 {120 to 150}

## Solenoid model codes

Power supply	Applicable wiring method	Model code of solenoid set	Model code of solenoid coil
DC	Terminal box type	LD-3P-10	C-LD-3P-10

Note: ○ The solenoid set comprises a solenoid coil, a solenoid cartridge, a plastic nut, and a push pin.

## Terminal box model code

Terminal box type

Voltage code	Spool operating method: Type C or D			Spool operating method: Type B				
	Without surge killer		Surge killer	Without surge killer		Surge killer		
P	TNW3-NP	(1)	TNW3-NP-N	(2)	TNW3-NP	(1)		
			TNW3-NP-NR				(3)	TNSB3-NP-N
							TNSB3-NP-NR	(3)

## Electrical Circuits

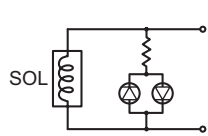
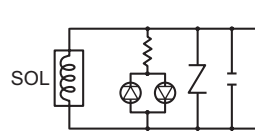
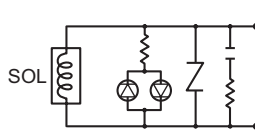
Standard	Surge killer	Surge killer with resistance
(1) 	(2) 	(3) 

Note: ○ When switching a DC solenoid valve with a surge killer using an electromechanical relay, the reverse surge voltage is suppressed by the varistor and sparks between relay contacts are suppressed by the capacitor at demagnetization of the solenoid.

Standard solenoid valves with a surge killer (option code "N") are very effective to eliminate sparks. However, adequate consideration should be given to the service life of the relay to avoid contact welding due to inrush current at solenoid excitation.

In applications where contact welding due to inrush current is expected, solenoid valves with a surge killer (with resistance) (option code "NR") are effective. Note, however, they are not as effective as standard solenoid valves with a surge killer (option code "N") in terms of elimination of sparks.

- When using solenoid valves without a surge killer, adequate consideration should be given to protection against the reverse surge voltage generated at demagnetization of the solenoid.

## Wiring guide

- The figure shows the status with the terminal box nameplate removed.
- The earth terminal is optional (option code: E).
- For double solenoid type valves, a short bar for common terminals is fitted to facilitate wiring. Connection to either terminal (3) or (4) is sufficient.

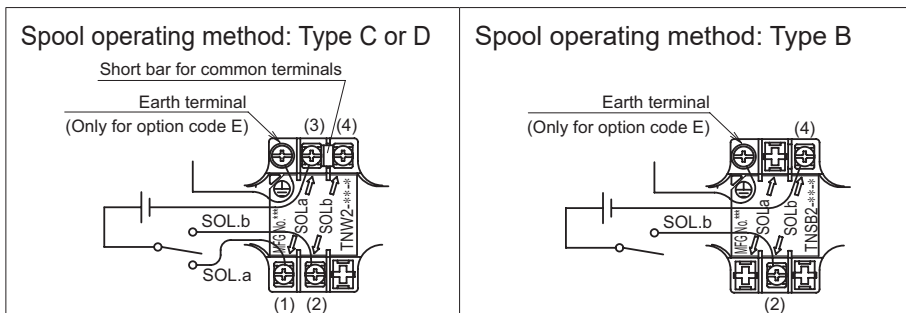

Note: ○ There is no polarity to consider when wiring a solenoid controlled valve.

- Always turn off the power supply before starting wiring work.
- User crimp-style terminals for M3.
- Tighten the terminal screws (M3) at a tightening torque of 0.34 to 0.51 N·m {3.4 to 5.1 kgf·cm}

## External dimension diagram

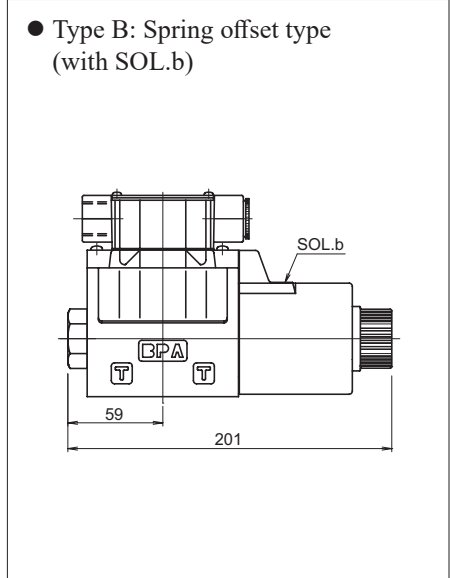
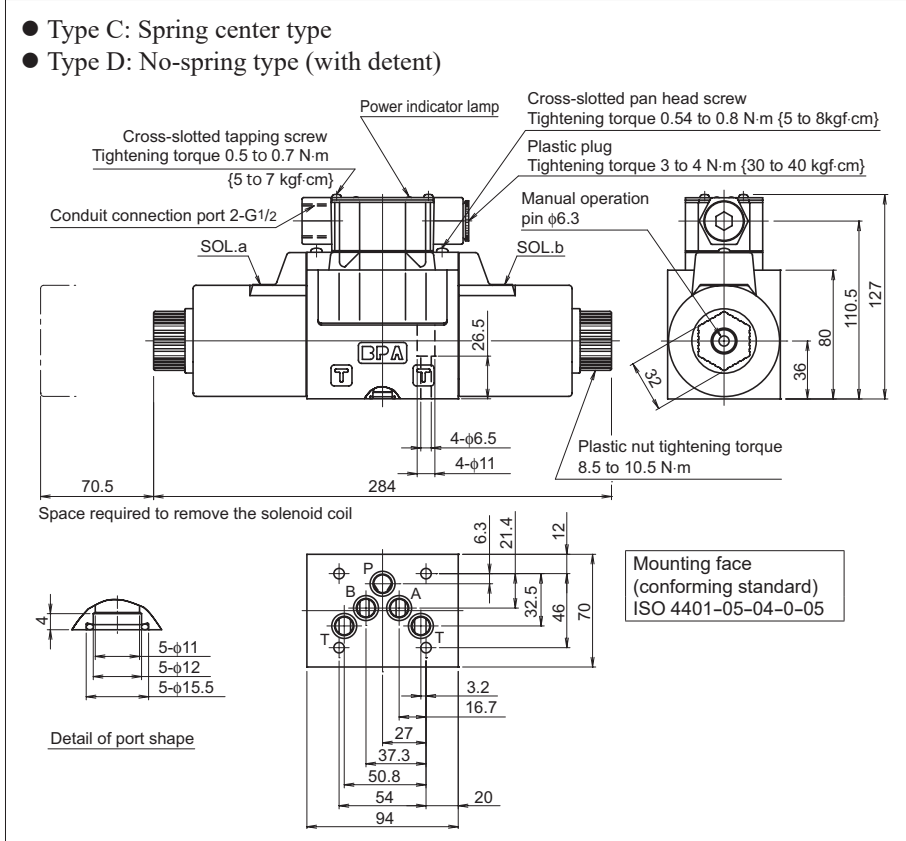

## Sectional structural diagram

LS-G03

●LS-G03-※CP-10

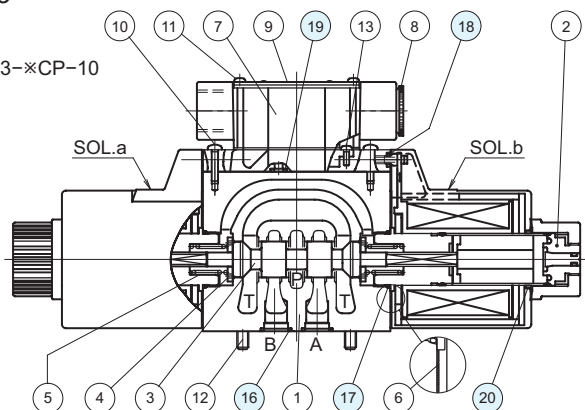

●LS-G03-※CP-10-E

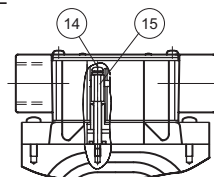

Sealing part table

Part No.	Name	Quantity	Part specifications
16	O-ring	5	AS568-014 (NBR, Hs90)
17	O-ring	2	AS568-022 (NBR, Hs90)
18	O-ring	4	JIS B2401 1A P4
19	O-ring	1	JIS B2401 1A P5
20	O-ring	2	S 26 (NBR, Hs70) Manufacturer: NOK