

Type C2 Low-pressure Reducing Valve

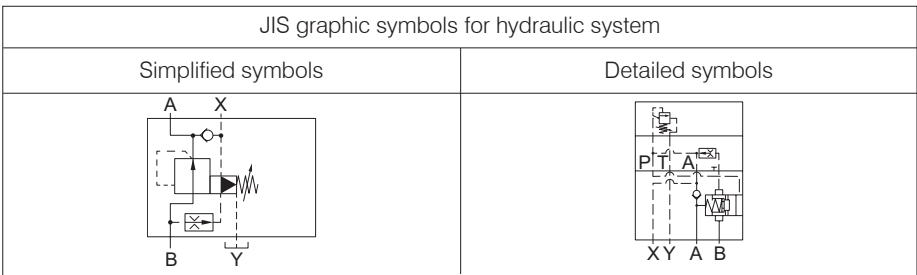
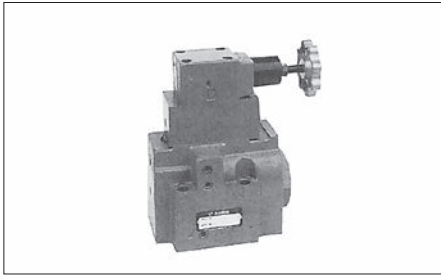

Features

- These normally closed type valves are capable of pressure control from the low pressure range because of a structure that supplies the pilot flow rate from the primary side of the valve to the built-in flow rate adjusting valve.

Nomenclature

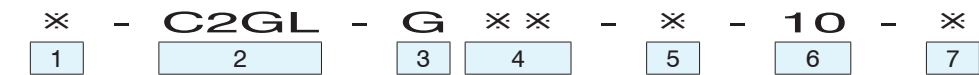

- | | |
|--|---|
| <p>1 Applicable fluid code
No designation: Petroleum-based hydraulic fluid, water-glycol hydraulic fluid
F: Phosphate ester hydraulic fluid</p> <p>2 Model No.
C2GL: Type C2 low-pressure reducing valve</p> <p>3 Connections
G: Gasket mount type</p> <p>4 Nominal diameter
03: 3/8
06: 3/4</p> | <p>5 Pressure adjustment range
1: Up to 7 MPa {Up to 70 kgf/cm²}
2: Up to 16 MPa {Up to 160 kgf/cm²}</p> <p>6 Design No.
(The design No. is subject to change)</p> <p>7 Option code
No designation: Pressure adjusting handle type
H: Pressure adjusting small handle type
F: Screw adjusting type with a cap</p> |
|--|---|

Specifications

Model code	Nominal diameter	Maximum operating pressure MPa {kgf/cm ² }	Pressure adjustment range*1 MPa {kgf/cm ² }	Maximum flow rate L/min	Drainage rate L/min	Mass kg
C2GL-G03-1-10	3/8	25 {250}	Up to 7 {Up to 70}	80	0.5 to 0.6	5.6
C2GL-G03-2-10			Up to 16 {Up to 160}			
C2GL-G06-1-10	3/4		Up to 7 {Up to 70}	160		8.4
C2GL-G06-2-10			Up to 16 {Up to 160}			

Note: *1 The minimum adjustment pressure varies depending on the flow rate. See the flow rate - pressure characteristics for details.

Model code	Pressure change MPa {kgf/cm ² } per handle revolution
C2GL-G※※-1	2.5 {25}/revolution
C2GL-G※※-2	4.6 {46}/revolution

Sub-plate model code

- The sub-plate is not provided with the valve. Order it separately as required by specifying the model code given in the table below.

Model code	Nominal diameter	Connection port diameter	Mass kg
JGB-03M	3/8	Rc3/8	1.6
JGB-03M04		Rc1/2	
JGB-06M	3/4	Rc3/4	3.9
JGB-06M08		Rc1	

Refer to Page S-7 for the dimensions of the sub-plate.

Accessories

Model No.	Hexagon socket head cap bolt	Quantity	Tightening torque N·m {kgf·cm}
C2GL-G03	M10 × 60	4	51 to 68 {510 to 680}
C2GL-G06	M10 × 75	4	51 to 68 {510 to 680}

Contact Details

Before using the product, please check the guide pages at the front of this catalog.

Internet

<https://www.daikinpmc.com/en/>

For latest information, PDF catalogs and operation manuals

Handling

- Directly connect the drain piping to the tank without merging it with other tank piping.
- To ensure good pressure reducing performance, set the primary side main circuit pressure and the secondary pressure reducing circuit pressure such that there is a minimum difference of 1 MPa {10 kgf/cm²}.
- When using the valve in combination with a direct operated relief valve for remote control, connect the remote control valve to the vent port.
Since excessive internal volume of the vent piping may lead to vibration, use steel pipes with an inner diameter of 4 mm maximum and thick walls for piping.

Performance curves (viscosity: 32 mm²/s {cSt})

● C2GL-G03

Flow rate - Pressure characteristics

Solid line: With a primary pressure of 25 MPa {250 kgf/cm²}

Dashed line: With a primary pressure of 16 MPa {160 kgf/cm²}

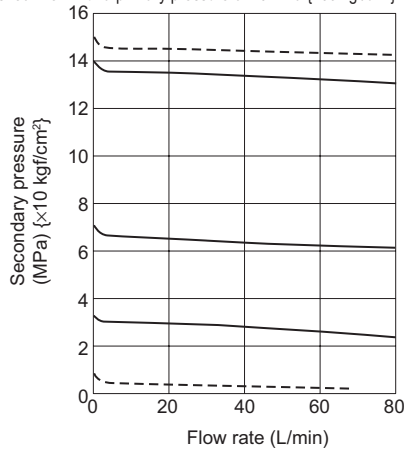

Flow rate - Pressure characteristics

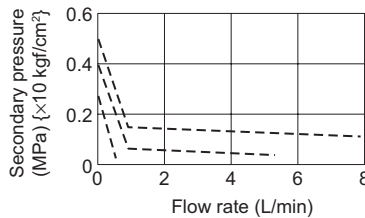

Note: The minimum adjustment pressure at 0 L/min is 0.15 MPa {1.5 kgf/cm²}.

Pressure drop characteristics

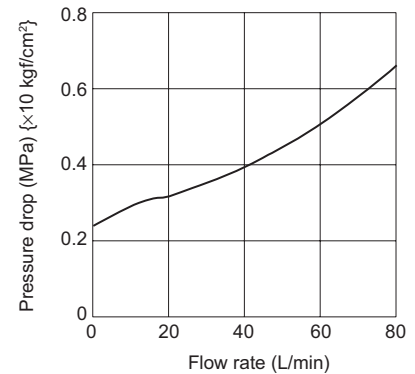

● C2GL-G06

Flow rate - Pressure characteristics

Solid line: With a primary pressure of 25 MPa {250 kgf/cm²}

Dashed line: With a primary pressure of 16 MPa {160 kgf/cm²}

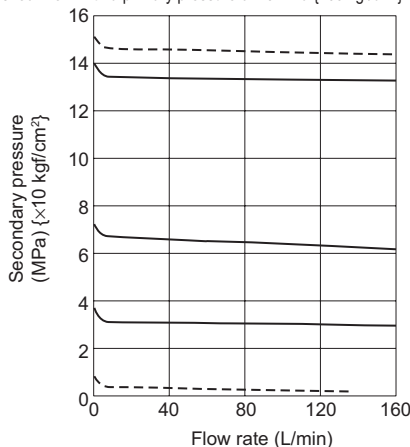

Flow rate - Pressure characteristics

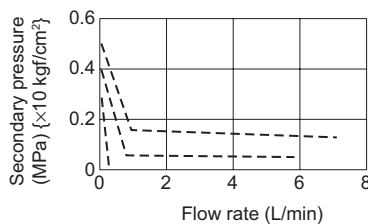

Note: The minimum adjustment pressure at 0 L/min is 0.15 MPa {1.5 kgf/cm²}.

Pressure drop characteristics

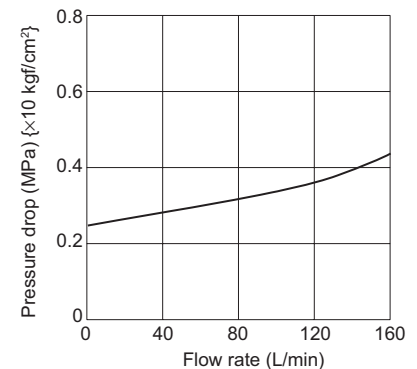

Contact Details

Before using the product, please check the guide pages at the front of this catalog.

Internet

<https://www.daikinpmc.com/en/>

For latest information, PDF catalogs and operation manuals

External dimension diagram

C2GL-G**

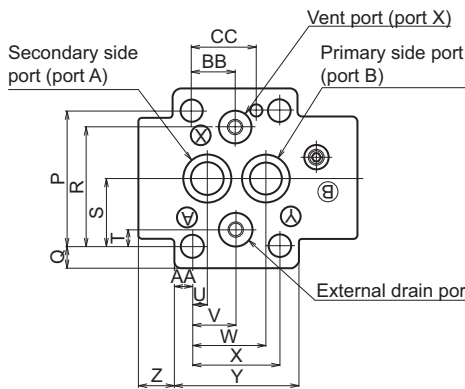
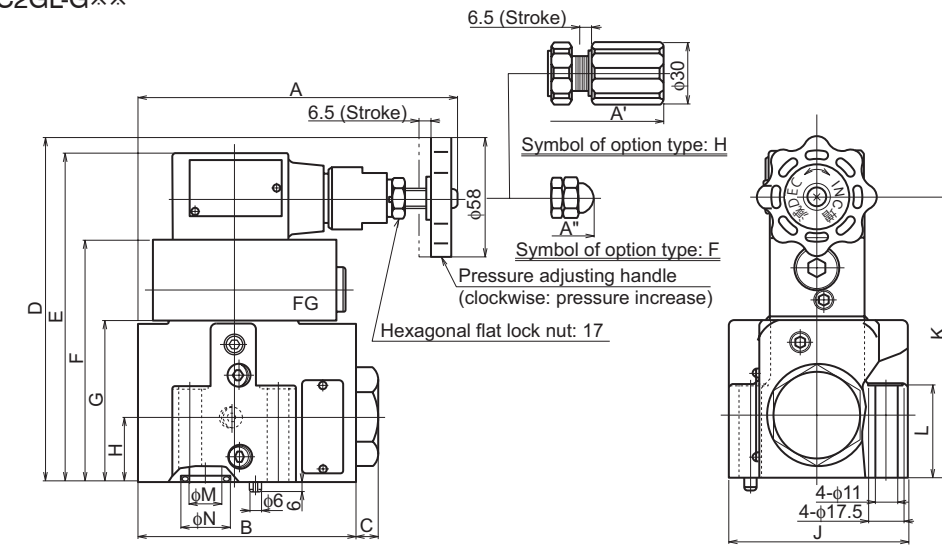

Model No.	Dimensions														
	A	A'	A''	B	C	D	E	F	G	H	J	K	L	M	N
C2GL-G03	157.8	182	147.5	107	11	166	159	117	77	30	88	137	44	16	24
C2GL-G06	167.3	191.5	157	127	14	184	177	135	95	40	102	155	59	24	34

Model No.	Dimensions													
	P	Q	R	S	T	U	V	W	X	Y	Z	AA	BB	CC
C2GL-G03	66.7	10.65	58.7	33.3	7.9	7.1	21.4	35.7	42.9	61	17	9.05	21.4	31.8
C2GL-G06	79.4	11.3	73	39.7	6.4	11.1	39.7	49.2	60.3	82	16	10.85	20.8	44.5

Mounting face (conforming standard)
 C2GL-G03: ISO 5781-06-07-0-00
 C2GL-G06: ISO 5781-08-10-0-00

Sectional structural diagram

C2GL-G**

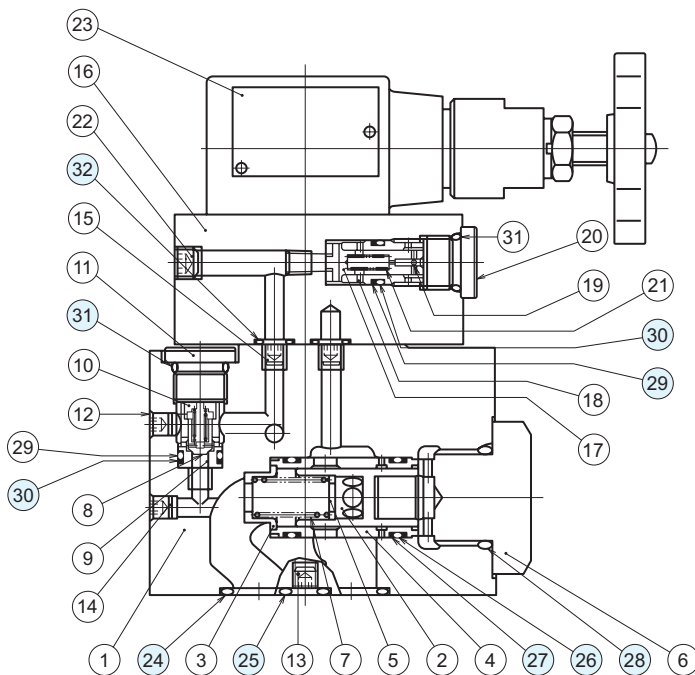

Sealing part table

Part No.	Name	Quantity	Part specifications	
			C2GL-G03	C2GL-G06
24	O-ring	2	JIS B 2401 1B P20	JIS B 2401 1B P28
25	O-ring	2	JIS B 2401 1B P12	JIS B 2401 1B P12
26	O-ring	2	AS568-020 (NBR, Hs90)	AS568-122 (NBR, Hs90)
27	Backup ring	4	Bias cut for AS568-020	Bias cut for AS568-122
28	O-ring	1	AS568-215 (NBR, Hs90)	AS568-222 (NBR, Hs90)
29	O-ring	2	AS568-013 (NBR, Hs90)	AS568-013 (NBR, Hs90)
30	Backup ring	2	Bias cut for AS568-013	Bias cut for AS568-013
31	O-ring	2	JIS B 2401 1B P14	JIS B 2401 1B P14
32	O-ring	4	JIS B 2401 1B P9	JIS B 2401 1B P9