

Portable Magnetic Base Drilling Machine

ATRA ACE manual feed

Model **LO-3550** 

• Max. 35 mm dia. x 50 mm deep

Compact, light weight, low profile design gives you greater hole making mobility

- Drilling on 100 mm or more width web and flange of wide flange beam
- Designed to improve drilling on walls, confined and elevated locations
- Drill position can be adjusted up to 10 mm travel on each axis straight front to back and pivot side to side



Specifications

Model		LO-3550		
Power Source (Single Phase)		220 - 240 V AC, 50/60 Hz		
Electric Drill	Rated Power Consumption	W	800	
	Rated Current	A	3.3	
	No-load Speed	min ⁻¹ (rpm)	950	
Hole Capacity mm	Cutter	Hole Diameter	Plate Thickness	
		One-touch Type JETBROACH 25L	12 to 17	6 to 25
		One-touch Type JETBROACH 35L	17.5 to 35	6 to 35
	One-touch Type JETBROACH 50L	12 to 35	6 to 50	
Magnet Holding Power		N(kgf)	5500 (561)	
Magnet Dimensions		mm	65 x 145	
Cutter Position	Pivot Side to Side	mm	10	
Adjustment	Straight Front to Back	mm	10	
Power Cord Length		m	3	
Mass (Weight)		kg	8.7*	

*Without an electric cord and a sub handle

Accessories Included

- Carry Case
- Cutting Oil 0.5L
- Feed Handle
- Sub Handle
- Pilot Pin 08035
- Spanner 17
- Blade
- Hex. Socket Bolt 5 x 12
- Hex. Socket Head Set Screw 8 x 28
- 4 mm Hex. Socket Screw Key
- 5 mm Hex. Socket Screw Key
- Spanner 7 x 8
- Guard
- Safety Strap

Chip Breaker



This chip breaker prevents the cutter from becoming jammed with metal shavings.

Optional Accessories

Ref. No.	PN	Description	Sales Unit
1	TB01507	Cutting Oil 2L	1 piece
2	TQ10581	Jet Oiler	
3	TB01098	Tube 4 x 7 x 3000 Ass'y	
4	TB07306	Lubrication Adapter Ass'y	
5	TB04374	Supporting Magnet Ass'y	
6	TB07696	Pipe Attachment Ass'y	
*50L for stacked plates			One-touch Type JETBROACH 25L, 35L, 50L



Easy Drilling Position Adjustment

After engaging the magnet, the drill position can be adjusted up to 10 mm travel on each axis straight front to back and pivot side to side.

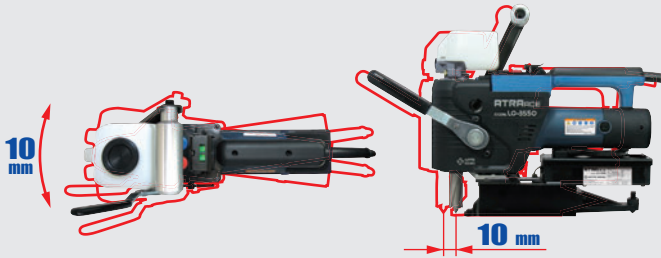

Adjustable Feed Handle

The feed handle can be locked at varying angles to enhance productivity.

Pull the feed handle to adjust the angle.

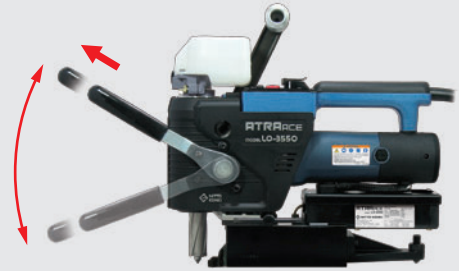

Light Handle Operation

Fast revolution of Jetbroach cutter makes less cutting resistance and smooth handling.

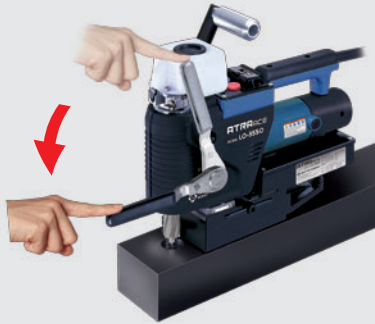

Easy-to-use Switch Panel

On / off buttons of the magnet and the drill motor are on the front panel and can be operated by one hand. Drilling conditions can be checked by lamp colors.

Motor Switch
The motor switch can be activated after the magnet switch is turned on.

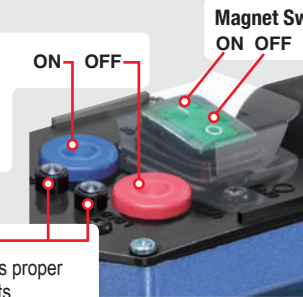

LED Load Indicator
The LED load display allows proper cutting pressure adjustments.

Reversible Feed Handle

The feed handle can be positioned on the right or left hand side for ease of drilling and mounting in confined spaces.

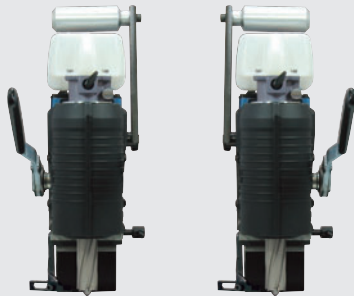

A Carrying Case Is Provided

The carrying case is a rugged accessory that provides a convenient way to transport and store the LO-3550.



Optional Accessories for ATRA ACE

Pipe Attachment Ass'y

The Pipe Attachment Ass'y is an optional base to securely fasten an Atra Ace on pipe for drilling. The chain can easily and securely fit around pipes having an outside diameter of 48.6 to 318.5 mm.

Example of installation on a pipe



Applicable Pipe Size:
48.6 to 318.5 mm

PN : TB07696

Applicable Models when a 35 mm or 50 mm length one touch type Jetbroach cutter is used:
CLA-2720, WOJ-3200, LO-3550, WA-3500, and QA-4000

Supporting Magnet Ass'y

If the accessory safety strap or chain is unable to be properly secured to prevent the Atra Ace from falling off the workpiece, the supporting magnet ass'y is recommended. It employs a permanent magnet and can secure the Atra Ace even if power is interrupted.

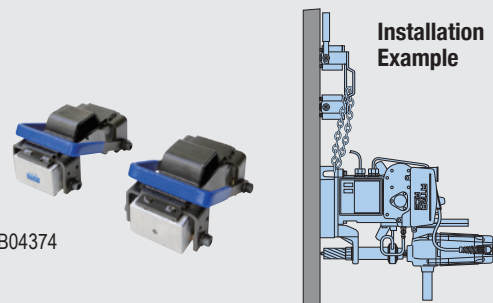

PN : TB04374

Applicable Models:
CLA-2720, LO-3550, WA-3500, WOJ-3200, AO-5575A, QA-4000, and QA-6500