

# BABY BELTON

**Model: BB-10B**

## INSTRUCTION MANUAL

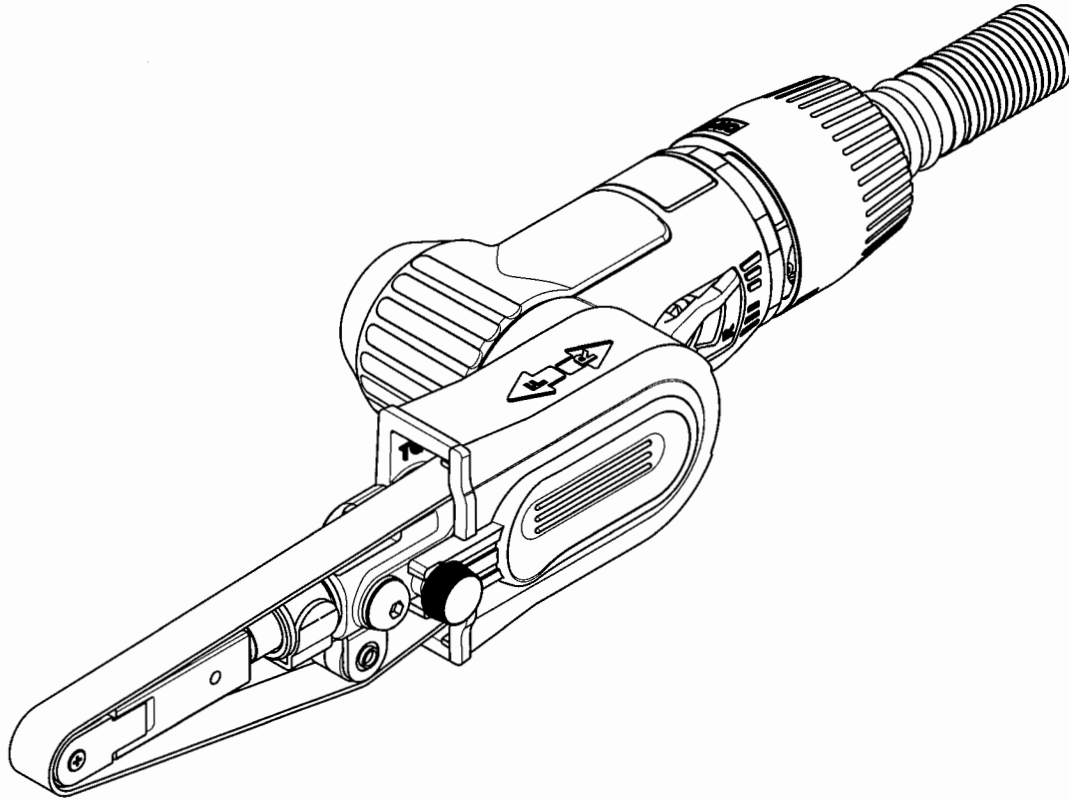

### <Specifications>

Model		BB-10B
Maximum Operating Pressure	MPa	0.6
Air Consumption (No Load)	m <sup>3</sup> /min	0.2
Rated Speed (No Load)	min <sup>-1</sup>	17000
Standard Belt Size	mm	10×330 (25/64"×13")
Mass (Weight)	kg	0.5
Sound Pressure Level	dB(A)	81
Sound Power Level	dB(A)	92
Vibration Level [Uncertainty K]	m/s <sup>2</sup>	0.87 [0.29]
Thread Size of Air Inlet		Rc 1/4

\*1. Based on the ISO15744 measurement standard.

\*2. Based on the 3 axes combined value measurement standard of the ISO28927-3 of the hand-tool frequency correction vibration acceleration effective value.

- Please read this manual carefully before you attempt to use your tool so that you may use it properly and safely.
- Please keep the manual handy - so you can use it whenever necessary.

• Due to continuous product development/improvement the specifications and configurations in this document are subject to change without prior notice.

## Instructions

Thank you very much for your purchase of this NITTO KOHKI product.  
Before using your tool, please read this manual carefully so that you may use it properly to get the most out of it.  
Please keep the manual handy - so you can use it whenever necessary.

- English : Please ask your dealer or distributor for instruction manual in local language(s).
- German : Bitte fragen Sie Ihren Händler nach eine Betriebsanleitung in Landessprache.
- French : S'il vous plait, veuillez demandez á votre fournisseur de manuel instruction en langue locale.
- Spanish : Por favor, contacte con su distribuidor para el manual de instrucciones en español.
- Portuguese : Por favor pessa ao seo agente ou distribuidor o manual de instrucces ih linguagen local.
- Italian : Per Manuale Istruzioni in lingua locale Vi preghiamo di rivolgervi al rivenditore o distributore.
- Dutch : Vraag uw handelaar om een nederladstalige gebruiksaanwijzing.
- Swedish : Be er lokala Åtreförsäljare eller distributör om manualer på svenska.
- Danish : Venligst henvend Dem til den danske distributør for instructions manualer.
- Polish : Proszę pytać swojego dealera lub dystrybutora o instrukcje obsługi w języku localnym.
- 中文 : 請向當地供應商或經銷商詢問中文使用說明書

The following Safety notations are used throughout the manual to highlight safety precautions for the user and for the tool.



### **WARNING:**

Indicates a potentially hazardous situation which, if not avoided by following the instructions given, could result in death or serious injury.



### **CAUTION:**

Indicates a potentially hazardous situation which, if not avoided by following the instructions given, could result in injury or material damage.

\* Please note, however, that failure to observe safety precautions under the “ CAUTION” category could result in a serious occurrence depending on the situation.  
Please observe all safety precautions in the manual.

**CAUTION:** Important precautions for tool setup, operation and maintenance.

### About pictograms



**WARNING:** It might be dangerous to operate the tool if the instructions supplied are not followed.



Using this tool improperly could result in serious injury. Read the instruction manual before using.



Always wear suitable eye protection.



Always wear suitable hearing protection.



Always wear respiratory protective equipment (PPE).

## Contents

Precautions on Use (Make sure to follow the instructions given).....	1	Offset Bracket .....	14
1 Application.....	9	Relocation of Throttle Lever.....	15
2 Checking Inside the Package.....	9	6 Basic Operation.....	15
3 Part Names .....	10	Sanding Operation.....	15
4 Air Supply.....	11	7 Maintenance and Inspection .....	16
5 Preparation.....	12	Storing the tool.....	16
Start and Stop.....	12	Disposal .....	16
Switching the rotating direction and adjusting the rotation speed .....	13	8 Optional Parts .....	16
Changing the abrasive belt .....	13	9 Ordering Parts.....	16
Adjusting the Tracking.....	14		

## California Proposition 65

### ⚠ WARNING

Some dust created by power sanding, sawing, grinding, drilling, and other construction activities contains chemicals known [to the State of California] to cause cancer birth defects or other reproductive harm.

Some examples of these chemicals are:

- Lead from lead-based paints,
- Crystalline silica from bricks and cement and other masonry products, and
- Arsenic and chromium from chemically-treated lumber.

Your risk from these exposures varies, depending on how often you do this type of work. To reduce your exposure to these chemicals: work in a well ventilated area, and work with approved safety equipment, such as those dust masks that are specially designed to filter out microscopic particles.

## Precautions on Use (Make sure to follow the instructions given)

Before using your tool, to avoid personal injury always take the basic precautions explained in later sections.

## General Power Tool Safety Warnings

### Personal safety

#### ⚠ WARNING

- **Dress properly.**

Do not wear loose clothing or jewelry. There is a danger of being caught in moving parts. Wear a pair of non-slip shoes. If your hair is long, wear a protective hair covering to contain your hair.

- **Always wear eye protection.**

Corrective glasses are not considered eye protection. Always wear appropriate eye protection.

- **Wear a dust mask.**

When dust is generated in the workplace, wear a dust mask.

- **Use a dust collector or dust collection equipment correctly.**

If a dust collector or dust collection equipment are being used, check that these are connected and used properly. Use of a dust collector can reduce risk caused by dust.

- **When loud noise is generated in the workplace, wear a hearing protection.**

- **Do not overreach.**

Keep proper footing and balance at all times.

- **Be on your guard when working.**

Do not use the tool when you are tired.

When you use the tool, be sure about the handling method, how to work, and pay sufficient attention to the surrounding environment.

- **Never touch the tip of moving parts when the tool is running.**

Also, do not direct the tip of moving parts toward people or animals.

- **Be aware of tool vibration and recoil. Some tools can cause a considerable amount of vibration.**

Depending on how the product is operated, the type of tool setting, and the length of operation, it could place a tremendous burden on your hands, arms and body.

The tool could cause a vibration injury or tendonitis. Avoid long-term use and take appropriate breaks.

Consult a doctor if you experience any discomfort or pain while operating the tool.

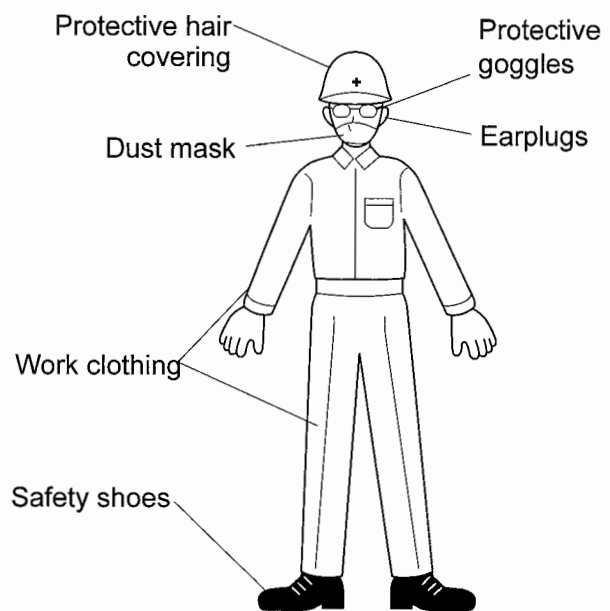

## Work area safety

### ⚠ WARNING

- **Do not use the tool at home.**  
This is a professional tool (industrial or work tool for business). Do not bring the tool home and use it there.
- **Keep the work area clean.**  
Working in a messy work area or work table could cause an accident.
- **Be cautious about the work area.**  
Do not expose the tool to rain.  
Do not use the tool in a damp or wet place.  
Keep the work area well lit.
- **Do not operate the tool in an explosive atmosphere, such as in the presence of flammable liquids (thinner, lacquer, gasoline, etc.) or gas.**
- **Do not let children come close to the work area.**  
Keep children and bystanders away while operating tool.
- **Some tools generate loud noise.**  
Check that the noise regulations of each area are complied with.
- **When work has to be done in high locations, make sure there is nobody underneath the work area.**  
If the tool or material is dropped, it could cause an accident or injury.
- **Before starting operation, make sure that there is no conduit, water pipe or gas pipe by your work area.**  
If a tool touches a buried object, it could cause electrical shock or leakage, which could cause an accident.

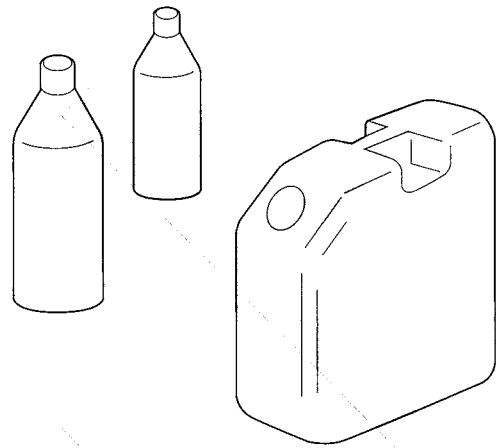

## Before starting to work

### ⚠ WARNING

- **Perform inspection before using the tool.**  
Before using the tool, check for loose screws on the tool and for damage on the protective cover or other parts, and make sure that the tool operates normally and demonstrates prescribed functions.  
Check the position adjustment and tightening status of moving parts, parts damage, attachment status, and all other locations for issues that could affect operation.  
For parts replacement and repair, follow the instructions indicated in the instruction manual.  
If there are no instructions in the instruction manual, contact the retailer where you purchased the tool or the nearest NITTO service member store.  
Do not use the power tool if the switch does not turn it ON and OFF.
- **Make sure to properly attach the tip tool.**  
If the tip tool is not attached properly, there is a risk of jumping out or damage, which could result in injury.
- **After adjustment, be sure to remove tools such as spanners, wrenches, etc.**
- **Use appropriate tools.**  
Do not force small tools to do the job of a heavy duty tool. Do not use tools for purposes not intended.
- **Do not use tools in an unreasonable manner.**  
When the specifications are followed, tools can be used efficiently and safely.
- **Secure workpieces.**  
Where possible use clamps or a vise to hold the work. It is safe to hold the workpieces by hand and both hands can be used for operation.

## Handling tools

### WARNING

- **Storing the tool**

When the tool is not used, store the tool in a dry location. Also, store the tool out of the reach of children. For some tools, the storage temperature and humidity are specified. Store the tool in an appropriate location.

- **Be cautious about how the tool is carried.**

Do not carry the tool with your hand touching the operation switch.

- **Do not leave the tool while the tool is still running.**

Do not leave the work area until you turn off the operating switch, remove the power source and the tool completely stops.

- **Do not allow the following chemicals to come into contact with the tool, as parts could deteriorate.**

Acetone, benzene, thinner, ketone, ether, trichloroethylene and other similar chemicals

## Maintenance and Inspection

### WARNING

- **Do not disassemble or alter the tool.**

Using the tool after disassembling or remodeling it could cause an accident or injury.

- **Inspect tip tools and accessories.**

Always inspect tip tools and accessories for damage or deterioration before attaching them to the tool.

If damage or deterioration is found, request repair from the retailer where you purchased the tool or the nearest NITTO service member store.

- **Inspect for damaged sections.**

Sufficiently check for damage on accessories or other parts, that the tool operates normally, and that work can be performed appropriately.

If there are accessories or parts that have been damaged or could hinder work, request repair from the retailer where you purchased the tool or the nearest NITTO service member store.

- **Request repair from a dedicated store.**

For repair or replacement of parts, request service from the retailer where you purchased the tool or the nearest NITTO service member store.

Repair requires special knowledge and skills. If repair is performed at a place other than a specialty store, the tool may not demonstrate its full performance or it could lead to an accident or injury.

Request repair with the failed status kept intact. When requesting a repair, do not throw away damaged parts. It could be important information for investigating the failure cause so do not change the status.

- **Use genuine parts.**

If inappropriate parts are used, it could cause accident or injury.

- **Genuine parts are listed in the instruction manual or brochure. Inquire at the retailer where you purchased the tool or the nearest NITTO service member store.**

- **Do not remove the labels or plates on the tools.**

If labels or plates are broken or peeling, for a replacement label or plate contact the retailer where you purchased the tool or the nearest NITTO service member store.

## General Pneumatic Tool Safety Warnings

---

### WARNING

- **Use the tool with proper air pressure.**

If the air pressure is high, the rotation speed and reciprocation frequency become faster, causing damage such as damage or accelerated wear. Also, unexpected accidents could occur.

- **Connect the tool to air piping.**

In some factories, other than air piping, there may be other piping such as oxygen, nitrogen, gas, etc. Before connecting to piping, make sure it is the correct piping.

- **Do not start the tool carelessly.**

Turn off the operation switch, then attach the Connecting Hose to the tool.

- **When attaching, removing, and maintaining accessories, make sure to detach the Connecting Hose from the tool.**

- **Be cautious about exhaust.**

Pneumatic tool exhaust contains oil and drainage, etc. Be careful about the exhaust direction so that the exhaust does not directly hit people nearby.

- **Do not allow sources of electricity to touch the tool.**

The pneumatic tool is not insulated against contact by electric sources. Because there is a risk of electric shock, do not allow sources of electricity to touch the tool.

### CAUTION

- **Handle the tool with care.**

Rough handling could cause accidents or malfunctions. Do not exert an impact on the tool by throwing or dropping it.

- **Handle the Connecting Hose with care.**

Do not carry the tool by holding the Connecting Hose, and do not pull the Connecting Hose to remove it.

## Safety Warnings for PNEUMATIC SANDER

---

The following warnings are those required to be displayed as instructed by ISO11148-8.

### General Safety Rules

#### WARNING

- **For multiple hazards, read and understand this instruction manual before installing, operating, repairing, maintaining, changing accessories on, or working near this tool. Failure to do so can result in serious bodily injury.**

- **Only qualified and trained operators should install, adjust or use this tool.**

- **Do not modify this tool. Modifications can reduce the effectiveness of safety measures and increase the risks to the operator.**

- **Do not discard this instruction manual; hand it to the operator.**

- **Do not use this tool if the tool has been damaged.**

- **This tool shall be inspected periodically to verify the ratings and markings. When a label/nameplate is damaged, worn or missing, contact the sales agent through which you have purchased your tool or NITTO KOHKI Co. Ltd. directly for a replacement.**

## Projectile Hazards

### WARNING

- Be aware that failure of the workpiece or accessories, or even of the inserted tool itself can generate high-velocity projectiles.
- Always wear impact-resistant eye protection while operating this tool. The grade of protection required should be assessed for each operation.
- For overhead work, wear a safety helmet.
- The risks to others should also be assessed at this time.
- Ensure that the workpiece is securely fixed.

## Entanglement Hazards

### WARNING

- Choking, scalping and/or lacerations can occur if loose clothing, personal jewelry, neckwear, hair or gloves are not kept away from the tool and its accessories.

## Operating Hazards

### WARNING

- Use of this tool can expose the operator's hands to hazards, including cuts, abrasions and burns. Wear suitable gloves to protect hands.
- Operators and maintenance personnel shall be physically able to handle the bulk, weight and power of the tool.
- Hold the tool correctly; be ready to counteract normal or sudden movements and have both hands available.
- Maintain a balanced body position and secure footing.
- Release the start-and-stop device if the energy supply is interrupted.
- Use only lubricants recommended by the manufacturer.
- Personal protective safety glasses shall be used; suitable gloves and protective clothing are recommended.
- Inspect the backing pad before each use. Do not use if cracked or broken or if it has been dropped.
- Avoid direct contact with the moving sanding pad in order to prevent pinching or cutting of hands or other body parts. Wear suitable gloves to protect hands.
- Never run the tool unless an abrasive is applied to the workpiece.
- There is a risk of electrostatic discharge if used on plastic and other non-conductive materials.
- Potentially explosive atmospheres can be caused by dust and fumes resulting from the use of this tool. Always use dust extraction or suppression systems which are suitable for the material being processed.

## Repetitive Motion Hazards

### WARNING

- When using this tool to perform work-related activities, the operator may experience discomfort in the hands, arms, shoulders, neck or other parts of the body.
- While using this tool, the operator should work in a comfortable posture while maintaining secure footing and avoiding awkward or off-balance postures. The operator should change posture during extended tasks; this can help avoid discomfort and fatigue.
- If the operator experiences symptoms such as persistent or recurring discomfort, pain, throbbing, aching, tingling, numbness, burning sensations or stiffness, these warning signs should not be ignored. The operator should tell their employer and consult a qualified health professional.

## Accessory Hazards

### WARNING

- Disconnect the tool from the energy supply before fitting or changing the inserted tool or accessory.
- Avoid direct contact with the inserted tool during and after use, as it can be hot or sharp.
- Use only accessories and consumables that are the sizes and types recommended by the manufacturer of this tool; do not use accessories or consumables of other types or sizes.
- Grinding wheels and cutting-off tools shall not be used.
- Check that the maximum operating speed of the inserted tool (flap wheels, abrasive belts, fiber discs, backing pads, etc.), is higher than the rated speed of the sander or polisher.
- Self-fixing sander discs shall be placed concentrically on the supporting pad.

## Workplace Hazards

### WARNING

- Slips, trips and falls are major causes of workplace injury. Be aware of slippery surfaces caused by the use of the tool and also of trip hazards caused by the air line or hydraulic hose.
- This tool is not intended for use in potentially explosive atmospheres and is not insulated against contact with electric power.
- Ensure that there are no electrical cables, gas pipes, etc., which can cause a hazard if damaged by the use of the tool.

## Dust and Fume Hazards

### WARNING

- Dust and fumes generated when using this tool can cause ill health (for example cancer, birth defects, asthma and/or dermatitis); risk assessment and implementation of appropriate controls for these hazards are essential.
- Risk assessment should include risks such as the dust created by the use of the tool and the potential for disturbing existing dust.
- Operate and maintain this tool as recommended in these instructions to minimize dust or fume emissions.
- Direct the exhaust so as to minimize disturbance of dust in a dust-filled environment.
- Where dust or fumes are created, the priority shall be to control them at the point of emission.
- All integral features or accessories for the collection, extraction or suppression of airborne dust or fumes should be correctly used and maintained in accordance with the manufacturer's instructions.
- Select, maintain and replace the consumable or inserted tool as recommended in the instruction handbook to prevent an unnecessary increase in dust or fumes.
- Use respiratory protection in accordance with the employer's instructions and as required by occupational health and safety regulations.



## Noise Hazards

### WARNING

- Exposure to high noise levels can cause permanent, disabling hearing loss and other problems, such as tinnitus (ringing, buzzing, whistling or humming in the ears). Therefore, risk assessment and implementation of appropriate controls for these hazards are essential.
- Appropriate controls to reduce the risk can include actions such as damping materials to prevent workpieces from “ringing”.
- Use hearing protection in accordance with the employer’s instructions and as required by occupational health and safety regulations.
- Operate and maintain this tool as recommended in the instruction handbook to prevent an unnecessary increase in the noise level.
- Select, maintain and replace the consumable or inserted tool as recommended in the instruction handbook to prevent an unnecessary increase in noise.
- If this tool has a silencer, always ensure it is in place and in good working order when the tool is being operated.
- The noise-emission value in this manual is measured in accordance with ISO standards. Since the real value may change depending on the work condition, please use this tool with measurements in the actual condition.
- Please don’t operate beyond the time set by the region where the tool is used.

## Vibration Hazards

### WARNING

- Exposure to vibration can cause disabling damage to the nerves and blood supply of the hands and arms.
- Wear warm clothing when working in cold conditions and keep your hands warm and dry.
- If you experience numbness, tingling, pain or whitening of the skin in your fingers or hands, stop using this tool, tell your employer and consult a physician.
- Operate and maintain this tool as recommended in the instruction handbook to prevent an unnecessary increase in vibration levels.
- Hold the tool with a light but safe grip, taking account of the required hand reaction forces, because the risk from vibration is generally greater when the grip force is higher.
- The vibration-emission value in this manual is measured in accordance with ISO standards. Since the real value may change depending on the work condition, please use this tool with measurements in the actual condition. Please don’t operate beyond the time set by the region where the tool is used.

## Additional Safety Instructions

### WARNING

- Air under pressure can cause severe injury:
  - —always shut off air supply, drain hose of air pressure and disconnect tool from air supply when not in use, before changing accessories or when making repairs;
  - —never direct air at yourself or anyone else.
- Whipping hoses can cause severe injury. Always check for damaged or loose hoses and fittings.
- Whenever universal twist couplings (claw couplings) are used, lock pins shall be installed and whip check safety cables shall be used to safeguard against possible hose-to-tool or hose-to-hose connection failure.
- Do not exceed the maximum air pressure stated on the tool.
- Never carry an air tool by the hose.
- When a tool is taken permanently out of service, it is advised that the tool be disassembled and degreased, and parts be separated by material and recycled locally in the appropriate manner.

## Product Specific Safety Rules

---

### WARNING

- **Protect your body from chips.**

During grinding, hot chips scatter. Since it could cause blindness, respiratory disorders, burns or hearing impairment, when working, to protect your body use protective eyewear, a dust mask, earplugs, gloves (excluding knitted gloves), long-sleeved work clothes, etc. In addition, do not bring your face close to the tool.

- **When you change or adjust the tool or parts, be sure to detach the tool from the air hose.**

- **Never touch the moving parts while in operation.**

- **Always use the genuine Abrasive Belt for the belt sander BB-10B (Nitto Kohki Co., Ltd.).**

# 1 Application

This is a handheld pneumatic belt sander designed and built to perform sanding operation utilizing a abrasive belt.

# 2 Checking Inside the Package

When you open the package box, check the contents of the package and also check for any damage that may have occurred during transportation.

If an abnormality is found, request service from the retailer where you purchased the tool or the nearest NITTO service member store.

	Package Contents	Qty	Check
①	BB-10B main unit	1	
	Offset Bracket (on tool)	1	
②	Hex. Socket Screw Key 1.5	1	
③	Abrasive Belt Z #100×10; (on tool)	1	
	Abrasive Belt Z #120×10	1	
	Abrasive Belt Z #180×10	1	
	Abrasive Belt Z #240×10	1	

	Package Contents	Qty	Check
④	Bushing R 1/4×NPT 1/4	1	
⑤	Instruction Manual (this document)	1	
⑥	Caution for Use	1	

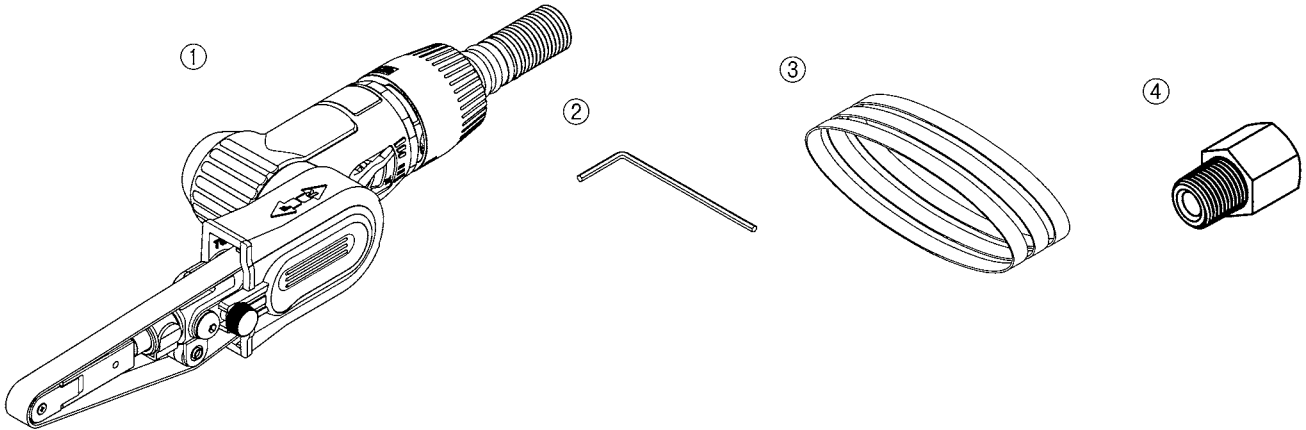

### 3 Part Names

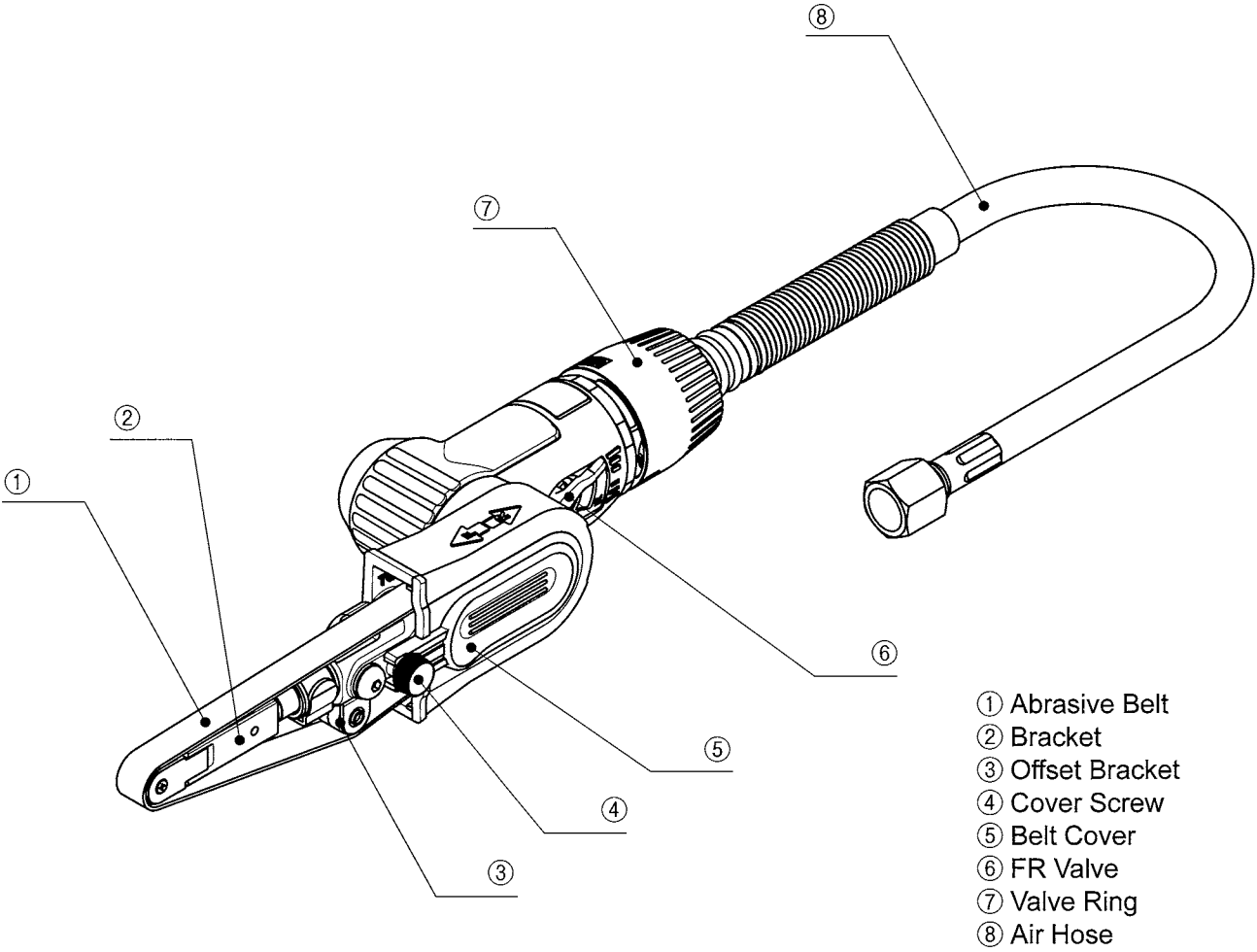

## 4 Air Supply

### ⚠ CAUTION

- Remove drainage before starting work.

When drainage enters the tool, the vicinity of the exhaust port freezes, which could cause a loss of power.

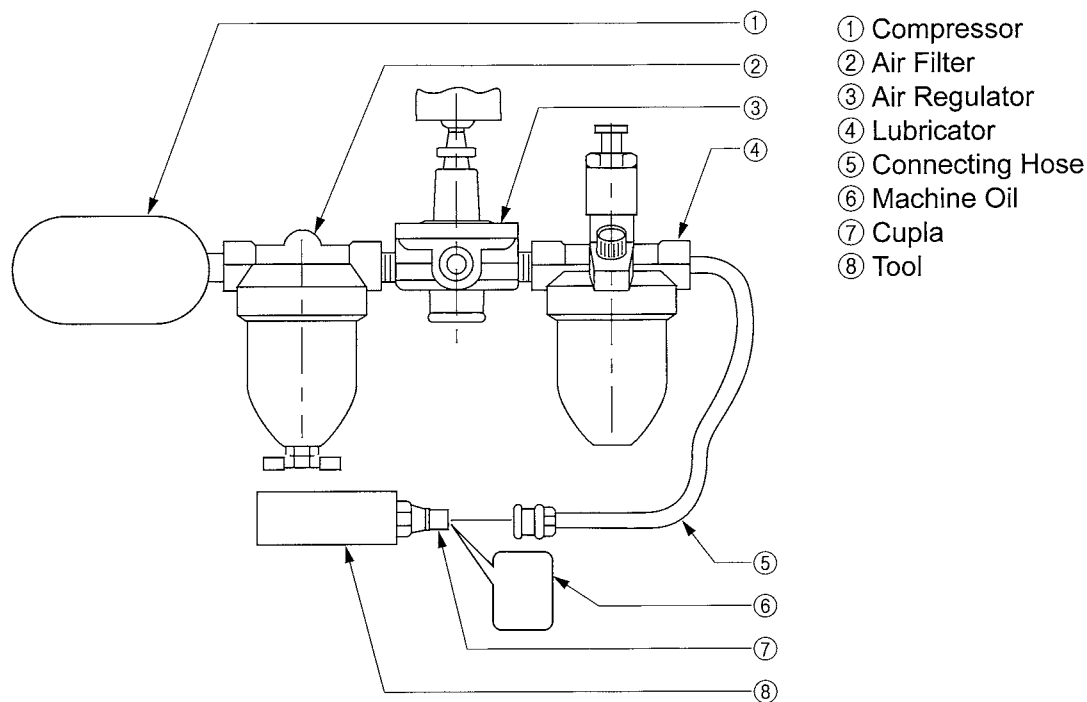

- ① Compressor
- ② Air Filter
- ③ Air Regulator
- ④ Lubricator
- ⑤ Connecting Hose
- ⑥ Machine Oil
- ⑦ Cupla
- ⑧ Tool

### Air pressure used

Use the tool with air pressure at 0.6 MPa. If the pressure is too low, the tool cannot demonstrate the required performance. If it is too high, it could damage parts of the tool. Use an Air Regulator (③) to adjust the pressure to the appropriate level.

### Air line

Use a Connecting Hose (⑤) with an internal diameter of 9.5 mm (3/8") between the Compressor (①) and the tool (⑧). Compressed air exits the Compressor and cools and moisture condenses. Some moisture could condense inside the Connecting Hose and get inside the tool, causing a malfunction. Install the Air Filter (②) and Lubricator (④) between the Compressor and the tool.

### Machine oil

Install a Lubricator between the Compressor and the tool, and be sure to use machine oil (ISO VG-10). Failure to do so could cause damage to the tool. Also, if lubricating oil with high viscosity is used, it could cause performance degradation.

### Refueling

Each day before starting work detach the Connecting Hose and refill a few drops of machine oil (ISO VG-10) (⑥) from the Coupler (⑦) to the tool.

After refueling, connect the Connecting Hose and perform idle operation for a few seconds to allow the oil to blend in the entire tool.

## 5 Preparation

### ⚠ WARNING

- **Protect yourself from dust and abrasive particles.**  
When sanding hot dust and abrasive particles fly off the workpiece: Always wear eye protection glasses, long sleeve protective clothing, gloves (except knitted gloves), foot and leg protection, etc. to protect yourself. Always keep your face away from the sanding surface.
- **When you change or adjust the tool or parts, be sure to detach the tool from the air hose.**
- **Never touch the moving parts while in operation.**
- **Always use the genuine Abrasive Belt for the belt sander BB-10B (Nitto Kohki Co., Ltd.).**

## Start and Stop

### Start

- 1 Check the valve ring (①) exists at the position where the green line (②) is seen.**  
If the green line (②) is seen, the valve ring is turned OFF.

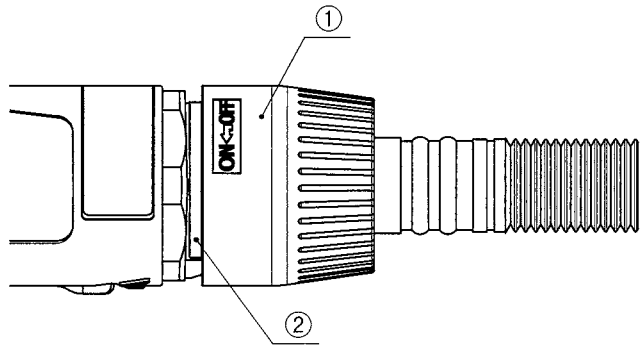

- 2 Connect the connection hose to the Cupla of this product. While pressing the valve ring against the direction (③), rotate it in anticlockwise direction (④).**  
The tool starts.

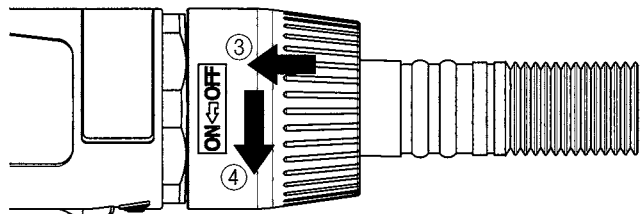

### Stop

- 1 Rotate the valve ring in clockwise direction.**  
The tool stops.

## Switching the rotating direction and adjusting the rotation speed

### Switching of rotating direction

Forward rotation and reverse rotation of abrasive belt are switched by rotating FR valve in Forward rotation side or reverse rotation side.

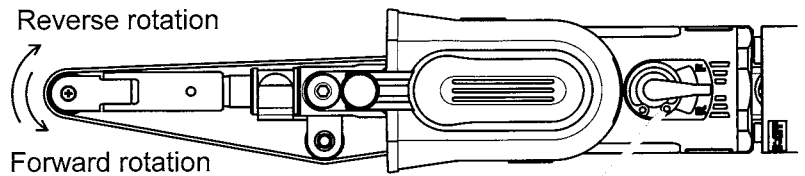

### Adjustment of rotation frequency

The rotation frequency of abrasive belt can be adjusted by the angle to rotate forward and reverse valve.

Adjust it according to the purpose of use.

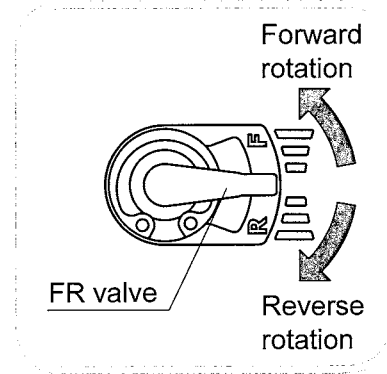

## Changing the abrasive belt

### ⚠ CAUTION

- Set the throttle lever to OFF and disconnect the tool from the connection hose before the replacement.
- Do it with gloves. Otherwise, you may get burned because the bracket becomes hot during grinding.
- Do not push the push button immoderately without attaching the abrasive belt. Otherwise, it may lead to a failure.
- At the replacement of abrasive belt, remove the abrasive powder around the drive pulley using an air blower etc.

- 1** Loosen the cover screw and remove the belt cover.
- 2** Lock the bracket by pressing it against the direction of arrow.
- 3** Replace the abrasive belt with a new one and push the push button. Then, the bracket will be unlocked.
- 4** Attach the belt cover surely and secure the cover screw.

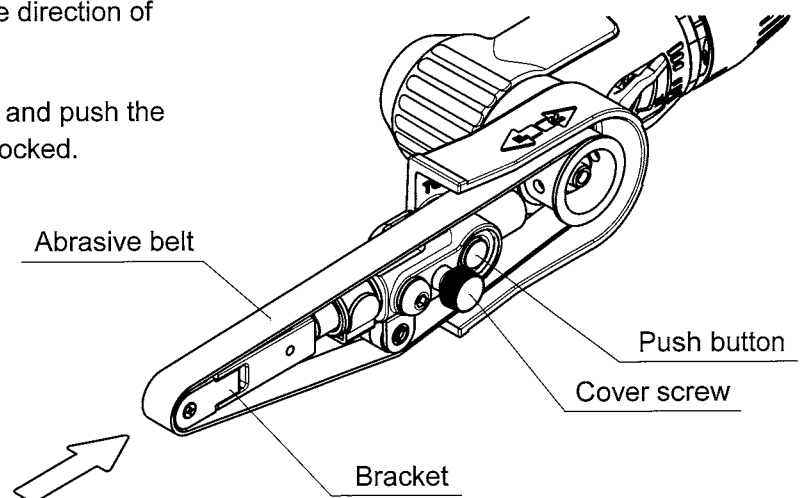

## Adjusting the Tracking

Loosen the Hex. Socket Set Screw by the Hex. Socket Screw Key 1.5 as shown in Fig. 6 and turn the adjusting screw with a Pan Head screwdriver so that the Abrasive Belt may run almost in the center of the Idle Pulley, then turn the Hex. Socket Set Screw by the Hex. Socket Screw Key to lock the adjusting screw.

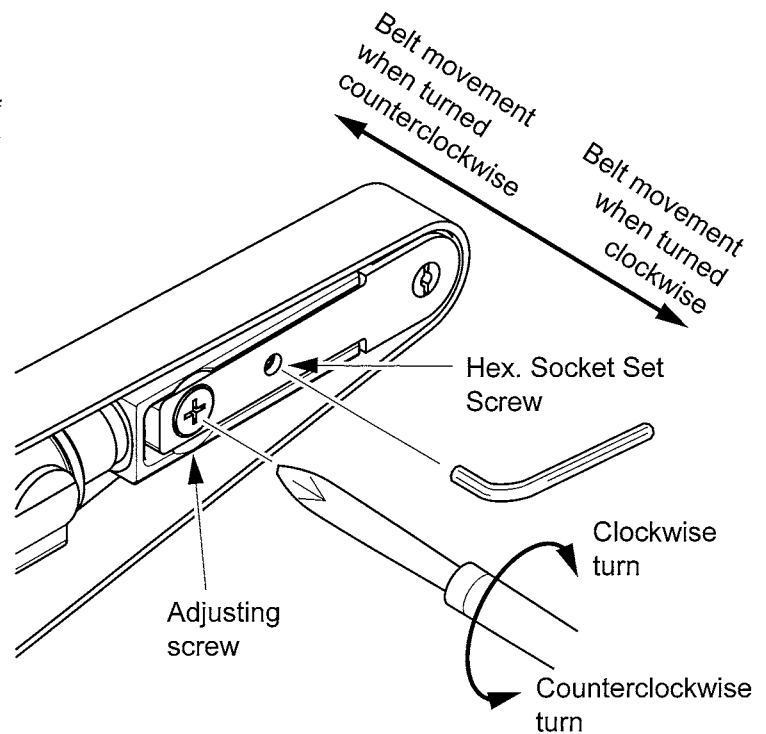

## Offset Bracket

The Offset Bracket is removable.

The original position as shown below is for the righthanded user. If you are left-handed (southpaw) user, first put Offset Bracket on the opposite side of the tool, and put the Idle Pulley Shaft and Throttle Lever facing to the other side. You can operate the tool as comfortable as the right-handed does.

- 1** Follow the belt replacement steps to remove the Cover and Abrasive Belt.
- 2** Pull out the Offset Bracket.  
At this time, you can pull it out smoothly by twisting it.
- 3** Insert the offset bracket in the opposite side.  
Push it all the way surely. Otherwise, the belt may drop off.
- 4** Mount Abrasive Belt and the Cover again.

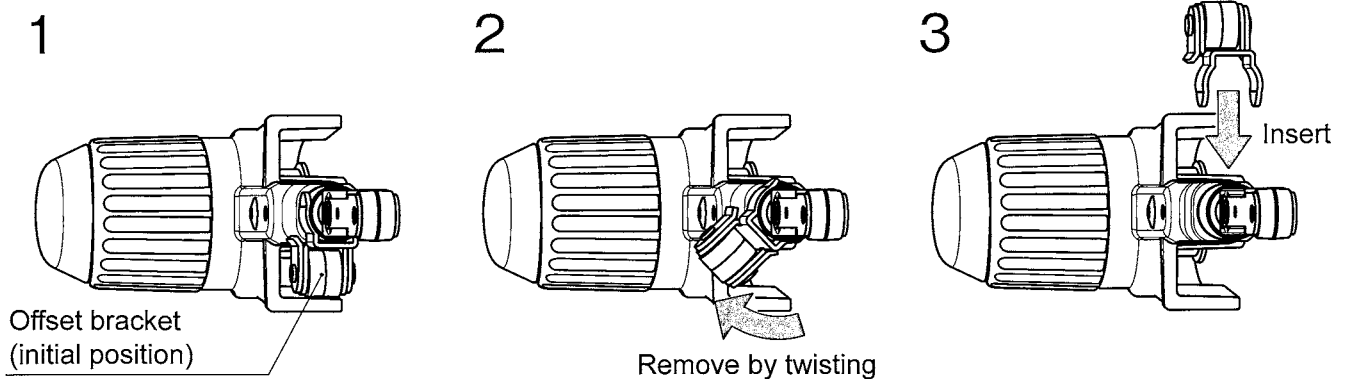



## 6 Basic Operation

### Sanding Operation

#### ⚠ CAUTION

- Do not press the Abrasive Belt too hard against the workpiece. If you do so, the Abrasive Belt may break.

Hold the tool with your hand to start. Lightly press the Abrasive Belt (between the Idle Pulley and the Offset Bracket) against a material to be sanded and keep on sanding.

You can select any sanding direction (forward or backward) by the FR Valve.

## 7 Maintenance and Inspection

### Storing the tool

Store the tool according to the following warnings and cautions.

#### ⚠ WARNING

- When the tool is not in use, store out of the reach of children.

#### ⚠ CAUTION

- When the tool is not in use, store in a place with little humidity.
- After completing work, lubricate with machine oil (ISO VG-10) from the Coupler of the tool and operate a little before storing.

If the tool is left as is after use, moisture in the air could remain inside the main unit, likely causing rust to occur.

### Disposal

- Separate the tool, accessories, and packing materials for environmentally-friendly recycling.
- When disposing of the tool, follow the rules of each municipality

## 8 Optional Parts

Abrasive Belt with various abrasives and grain sizes are separately prepared. Select them at your needs.

## 9 Ordering Parts

For further operational and handling information or for replacement of parts and components, contact the company from whom you purchased the tool or an authorized dealer.

In ordering parts and components give each part number, part name and quantity required. Use only NITTO genuine parts.